

LBASS15-15

Lavoce

15" BASS GUITAR WOOFER

FERRITE MAGNET
STEEL BASKET DRIVER



- 1.5 INCH VOICECOIL
- 96.5 dB/SPL SENSITIVITY
- 200 WATT PROGRAM POWER HANDLING
- OVERALL BALANCED AND RICH TONE
- SOLID LOW-END AND TIGHT MID-HIGH'S

GENERAL SPECIFICATIONS

Nominal diameter	mm (in.)	380 (15)
Nominal impedance	Ω	8
Minimum impedance	Ω	5,6
Program power (1)	W	200
AES Power rating (2)	W	100
Sensitivity (3)	dB	96,5
Frequency range	Hz	35 ÷ 4500
Voice coil diameter	mm (in.)	38 (1.5)
Chassis material		Steel
Magnet material		Ferrite
Magnet dimensions OD x ID x h	mm (in.)	110 x 45 x 17 (43.3 x 15.7 x 6.7)
Coil material		Copper
Former material		Glass fiber
Cone material		Water Proof Treated Paper
Surround material		Polycotton
Xmax (4)	mm (in.)	4,6 (0.18)
Xmech (5)	mm (in.)	8,6 (0.34)
Gap height	mm (in.)	8 (0.31)
Voice coil winding height	mm (in.)	13,3 (0.52)

SMALL SIGNAL PARAMETERS

DC resistance	Re	Ohm	5,2
Resonance frequency	Fs	Hz	34
Moving mass	Mms	g (oz)	64 (2.26)
Compliance	Cms	mm/N	0,34
Force factor	BxL	N/A	9,6
Mechanical Q-factor	Qms		4,4
Electrical Q-factor	Qes		0,77
Total Q-factor	Qts		0,66
Equivalent air volume	Vas	l (ft ³)	347 (12.2)
Voice coil Inductance	Le	mH	0,9
Diaphragm area	Sd	cm ² (in. ²)	855 (337)
Reference efficiency	Eta 0	%	1,76

SHIPPING INFORMATION

Net weight	Kg (lb.)	4,15 (8.9)
Multipack size (2)	mm x mm x mm (in. x in. x in.)	460 x 410 x 335 (18.1 x 16.1 x 13.9)
Multipack weight	Kg (lb.)	8,6 (19)

FREQUENCY RESPONSE

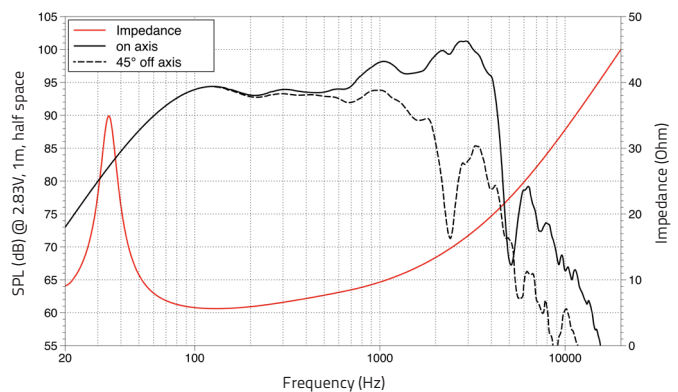

DIMENSIONS mm (in.)

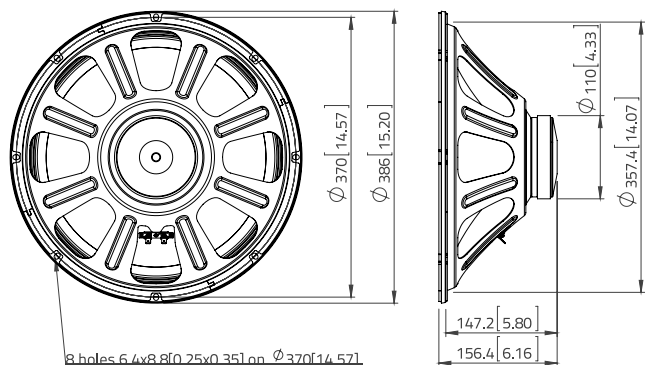

(1) Program power is defined as 3 dB greater than AES Power. (2) Tested for two hours using a continuous, band-limited pink noise signal as per AES 2-1984 Rev. 2003. Loudspeakers tested in free air. (3) From T/S parameters, measured with Klippel DA LPM module. (4) The Xmax is calculated as: $(Hvc - Hg)/2 + Hg/4$. Hvc is the voice coil height and Hg the gap height. (5) The Xmech is calculated as: $(Hvc - Hg)/2 + (Hg - 2)$. Hvc is the voice coil height and Hg the gap height. (6) Thiele-Small parameters are measured after preconditioning: a) at 20°C - 22°C, 50% humidity for 2 hours; b) by Klippel LSI measurement.

WWW.LAVOCESPEAKERS.COM



Lavoce Italiana

sales@lavocespeakers.com sales.cn@lavocespeakers.com