

CSF082.00K

Lavoce

8" COAXIAL

FERRITE COMMON HF\LF MAGNET
ALUMINIUM BASKET DRIVER

PRELIMINARY



- 2 INCH LF EDGEWOUND CCA VOICE COIL
- 1.4 INCH HF CCA VOICE COIL
- 96 dB/SPL SENSITIVITY
- 400 WATT PROGRAM POWER HANDLING
- FEM OPTIMIZED COMMON MOTOR, PHASEPLUG AND DIAPHRAGM
- 75 - 20000 Hz FREQUENCY RANGE
- 100° NOMINAL COVERAGE
- POLYIMIDE HF DIAPHRAGM
- DOUBLE ALUMINIUM DEMODULATING RING
- COMPACT AND LIGHTWEIGHT DESIGN

GENERAL SPECIFICATIONS

	LF	HF
LF Nominal diameter / HF Exit	mm (in.) 200 (8)	25.4 (1)
Nominal impedance	Ω 8	8
Minimum impedance	Ω 6,9	7,5
Program power (1)	W 400	70
AES Power rating (2)	W 200	35
Sensitivity (3)	dB 96	103,5
Frequency range	Hz 75 ÷ 5500	1500 ÷ 20000
Voice coil diameter	mm (in.) 50 (2)	35 (1.4)
Chassis material	Steel	
Magnet material	Ferrite	
Magnet dimensions	140 x 62 x 22	
OD x ID x h	(5.51 x 2.44 x 0.87)	
Coil material	Edgewound CCA	Edgewound CCA
Former material	Glass Fiber	Kapton
LF Cone / HF Dome material	Waterproof Treated Paper	Polyimide
Surround material	Polycotton	Polyimide
Flux density	T 1	1,5
Recommended crossover (4)	Hz -	2200
Xmax (5)	mm (in.) 5.3 (0.21)	-
Xmech (6)	mm (in.) 9.3 (0.37)	-
Gap height	mm (in.) 8 (0.31)	-
Voice coil winding height	mm (in.) 14.5 (0.57)	-
Driver displacement volume	l (ft³) 1.1 (0.04)	-
Recommended enclosure	l (ft³) 14.5 (.51)	-
Recommended tuning	Hz 90	-

LF SMALL SIGNAL PARAMETERS

DC resistance	Re	Ohm	5,7
Resonance frequency	Fs	Hz	76
Moving mass	Mms	g (oz)	17,3 (0.61)
Compliance	Cms	mm/N	0,25
Force factor	BxL	N/A	11,0
Mechanical Q-factor	Qms		3,5
Electrical Q-factor	Qes		0,39
Total Q-factor	Qts		0,35
Equivalent air volume	Vas	l (ft³)	16,9 (0.60)
Voice coil Inductance	Le	mH	0,48
Diaphragm area	Sd	cm² (in.²)	217 (33.64)
Reference efficiency	Eta 0	%	1,8
Efficiency bandwidth product	EBP	Hz	195

SHIPPING INFORMATION

Net weight	kg (lb.)	3 (6.6)
Multipack size (1)	mm	239 x 230 x 155
W x D x H	(in.)	(9.4 x 9 x 6.1)
Multipack weight	kg (lb.)	3,5 (7.7)

FREQUENCY RESPONSE AND IMPEDANCE

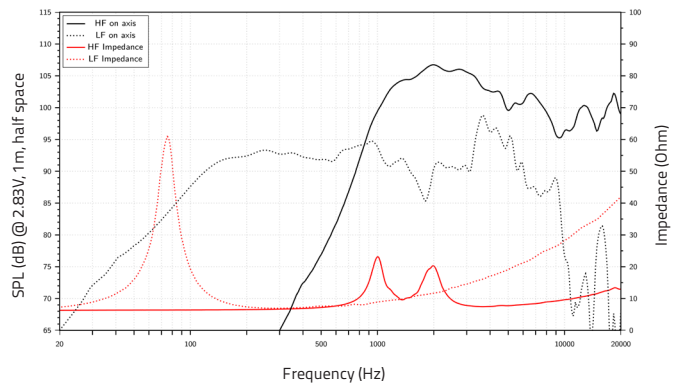

DIMENSIONS mm (in.)

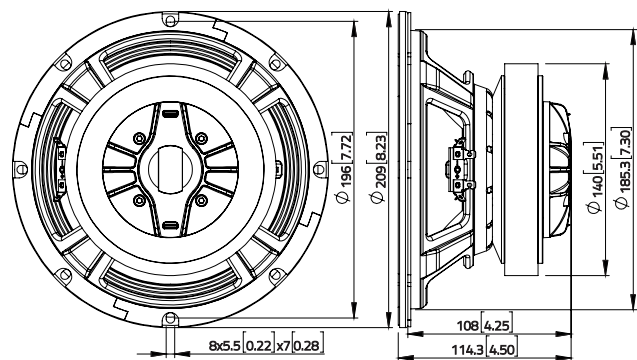

- (1) Program power is defined as 3 dB greater than AES Power.
- (2) Tested in free air for two hours using a continuous:
LF-band-limited pink noise signal as per AES 2-1984 Rev. 2003.
HF-band-limited (1000-20000 Hz, 12dB/oct.) pink noise signal as per AES 2-1984 Rev. 2003.
- (3) LF: From T/S parameters, measured with Klippel DA LPM module.
HF: Measured on axis at 2.83V, 1m, SPL averaged in the frequency range 1500 ÷ 20000 Hz.
- (4) High pass filter with slope 12dB/oct. or higher.
- (5) The Xmax is calculated as: $(Hvc - Hg) / 2 + Hg / 4$. Hvc is the voice coil height and Hg the gap height.
- (6) The Xmech is calculated as: $(Hvc - Hg) / 2 + (Hg - 2)$. Hvc is the voice coil height and Hg the gap height.
- (7) Thiele-Small parameters are measured after preconditioning: a) at 20°C - 22°C, 50% humidity for 2 hours; b) by Klippel LSI measurement.

All specifications subject to change without notice_E.a

WWW.LAVOCESPEAKERS.COM



Lavoce Italiana

sales@lavocespeakers.com sales.cn@lavocespeakers.com