

CAN143.00TH

Lavoce

13.5" COAXIAL

NEODYMIUM COMMON HF\LF MAGNET
ALUMINIUM BASKET DRIVER

PRELIMINARY

- 3 INCH LF COPPER VOICE COIL
- 3 INCH HF EDGEWOUND CCA VOICE COIL
- 99 dB/SPL SENSITIVITY
- 800 WATT PROGRAM POWER HANDLING
- FEM OPTIMIZED COMMON MOTOR, PATENTED IIS PHASEPLUG AND DIAPHRAGM
- 45 - 18000 Hz FREQUENCY RANGE
- 60°x40° NOMINAL COVERAGE
- COMPOSITE TITANIUM/POLYIMIDE HF DIAPHRAGM
- DOUBLE ALUMINIUM DEMODULATING RING
- COMPACT AND LIGHTWEIGHT DESIGN



GENERAL SPECIFICATIONS		LF	HF
LF Nominal diameter / HF Exit	mm (in.)	340 (13.5)	36 (1.4)
Nominal impedance	Ω	8	8
Minimum impedance	Ω	6,2	8
Program power (1)	W	800	160
AES Power rating (2)	W	400	80
Sensitivity (3)	dB	99	105
Frequency range	Hz	45 ÷ 4500	600 ÷ 18000
Voice coil diameter	mm (in.)	75 (3)	75 (3)
Chassis material		Aluminium	
Magnet material		Neodymium	
Magnet dimensions	mm	135 x 85 x 10	
OD x ID x h	(in.)	(5.31 x 3.35 x 0.39)	
Coil material		Copper	Edgewound CCA
Former material		Glass Fiber	Kapton
LF Cone / HF Dome material		WP Treated Paper + WP Front Side	Titanium
Surround material		Polycotton	Polyimide
Flux density	T	1,2	1,9
Recommended crossover (4)	Hz	-	1200
Xmax (5)	mm (in.)	6 (0.24)	-
Xmech (6)	mm (in.)	10 (0.39)	-
Gap height	mm (in.)	8 (0.31)	-
Voice coil winding height	mm (in.)	16 (0.63)	-
Driver displacement volume	l (ft ³)	3.5 (0.12)	-
Recommended enclosure	l (ft ³)	67.5 (2.4)	-
Recommended tuning	Hz	60	-

LF SMALL SIGNAL PARAMETERS

DC resistance	Re	Ohm	5,3
Resonance frequency	Fs	Hz	44
Moving mass	Mms	g (oz)	76,0 (2.68)
Compliance	Cms	mm/N	0,17
Force factor	BxL	N/A	19,1
Mechanical Q-factor	Qms		5,8
Electrical Q-factor	Qes		0,31
Total Q-factor	Qts		0,29
Equivalent air volume	Vas	l (ft ³)	123,7 (4.37)
Voice coil Inductance	Le	mH	0,50
Diaphragm area	Sd	cm ² (in. ²)	713 (110.52)
Reference efficiency	Eta 0	%	3,3
Efficiency bandwidth product	EBP	Hz	142

SHIPPING INFORMATION

Net weight	kg (lb.)	5,3 (11.7)
Multipack size (1)	mm	394 x 379 x 223
W x D x H	(in.)	(15.5 x 14.9 x 8.8)
Multipack weight	kg (lb.)	6,5 (14.3)

FREQUENCY RESPONSE AND IMPEDANCE

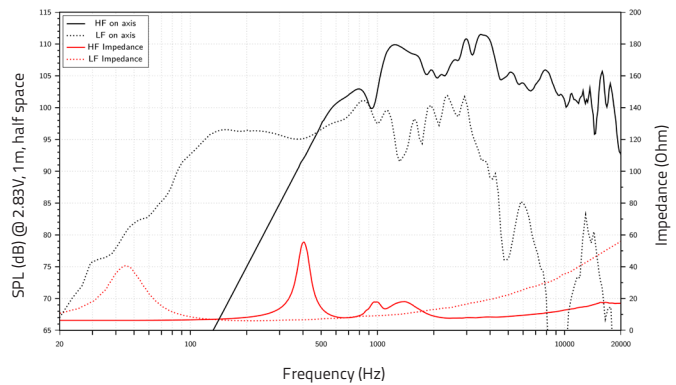

DIMENSIONS mm (in.)

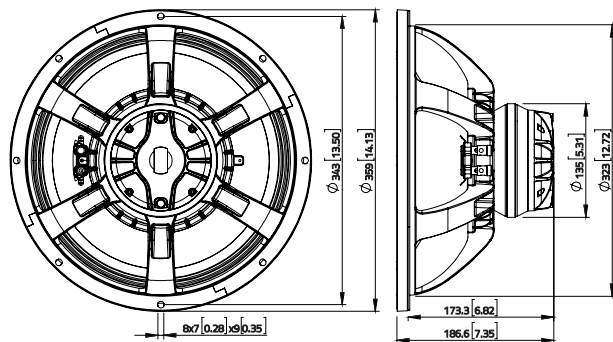

(1) Program power is defined as 3 dB greater than AES Power.

(2) Tested in free air for two hours using a continuous:

LF: band-limited pink noise signal as per AES 2-1984 Rev. 2003.

HF: band-limited (1000-20000 Hz, 12dB/oct.) pink noise signal as per AES 2-1984 Rev. 2003.

(3) LF: From T/S parameters, measured with Klippel DA LPM module.

HF: Measured on axis at 2.83V, 1m, SPL averaged in the frequency range 600 - 18000 Hz.

(4) High pass filter with slope 12dB/oct. or higher.

(5) The Xmax is calculated as: $(Hvc - Hg)/2 + Hg/4$. Hvc is the voice coil height and Hg the gap height.

(6) The Xmech is calculated as: $(Hvc - Hg)/2 - (Hg - 2)$. Hvc is the voice coil height and Hg the gap height.

(7) Thiele-Small parameters are measured after preconditioning: a) at 20°C - 22°C, 50% humidity for 2 hours; b) by Klippel LSI measurement.

All specifications subject to change without notice. E.a

WWW.LAVOCESPEAKERS.COM



Lavoce Italiana

sales@lavocespeakers.com sales.cn@lavocespeakers.com