



LBASS15-15

15" BASS GUITAR SPEAKER

Perfect for a bass practice amp, LBASS15-15 uses a triple roll surround and an optimized compact ferrite motor structure to deliver good efficiency and a wide frequency response.

100 W **1.5" VC** **96 dB** **35-4000 Hz**

GENERAL SPECIFICATIONS

Nominal diameter	mm (in.)	380 (15)
Nominal impedance	Ω	8
Minimum impedance	Ω	5,9
Program power (1)	W	200
AES Power rating (2)	W	100
Sensitivity (3)	dB	96
Frequency range	Hz	35 ÷ 4000
Voice coil diameter	mm (in.)	38 (1.5)
Chassis material		Steel
Magnet material		Ferrite
Magnet dimensions	mm (in.)	110 x 45 x 17 (4.33 x 1.77 x 0.67)
Coil material		Copper
Former material		Glass fiber
Cone material		Water Resistant Treated Paper
Surround material		Polycotton
Xmax (4)	mm (in.)	4,7 (0.19)
Xmech (5)	mm (in.)	8,7 (0.34)
Gap height	mm (in.)	8 (0.31)
Voice coil winding height	mm (in.)	13,3 (0.52)
Driver displacement volume	l (ft ³)	3,3 (0.12)
Recommended enclosure	l (ft ³)	85 (3.00)
Recommended tuning	Hz	Sealed

SMALL SIGNAL PARAMETERS

DC resistance	Re	Ohm	5,6
Resonance frequency	Fs	Hz	37
Moving mass	Mms	g (oz)	66,8 (2.36)
Compliance	Cms	mm/N	0,275
Force factor	BxL	N/A	9,89
Mechanical Q-factor	Qms		4,72
Electrical Q-factor	Qes		0,88
Total Q-factor	Qts		0,74
Equivalent air volume	Vas	l (ft ³)	284,84 (10.06)
Voice coil Inductance	Le	mH	0,88
Diaphragm area	Sd	cm ² (in. ²)	854,8 (132.5)
Reference efficiency	Eta 0	%	1,58
Efficiency bandwidth product	EBP	Hz	42

SHIPPING INFORMATION

Net weight	kg (lb.)	2,7 (6.1)
Multipack size (1)	mm (in.)	438 x 438 x 204 (17.2 x 17.2 x 8)
Multipack weight	kg (lb.)	4,1 (9.1)

FREQUENCY RESPONSE AND IMPEDANCE

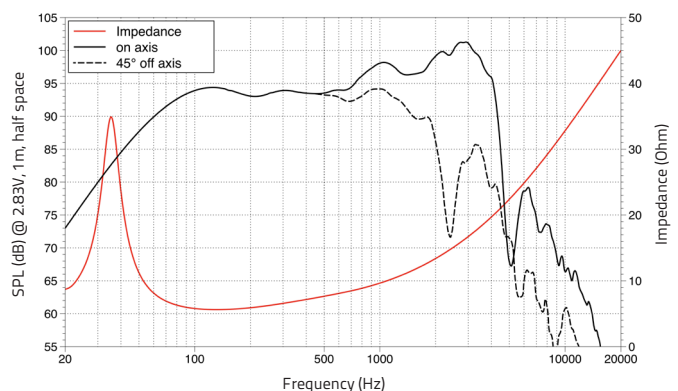

DIMENSIONS mm (in.)

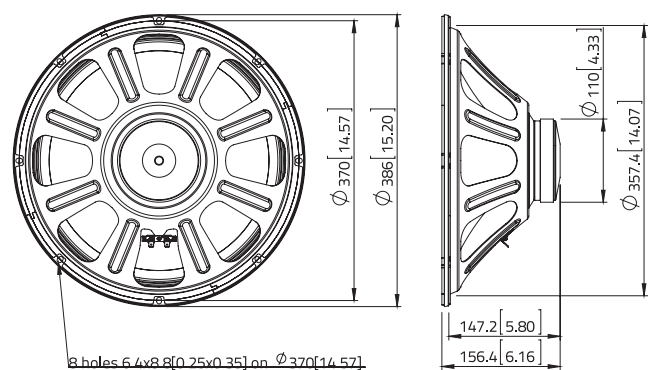

(1) Program power is defined as 3 dB greater than AES Power. (2) Tested for two hours using a continuous, band-limited pink noise signal as per AES 2-1984 Rev. 2003. Loudspeaker tested in free air. (3) From T/S parameters, measured with Klippel DA LPM module. (4) The Xmax is calculated as: $(Hvc - Hg)/2 + Hg/4$. Hvc is the voice coil height and Hg the gap height. (5) The Xmech is calculated as: $(Hvc - Hg)/2 + (Hg - 2)$. Hvc is the voice coil height and Hg the gap height. (6) Thiele-Small parameters are measured after preconditioning: a) at 20°C - 22°C, 50% humidity for 2 hours; b) by Klippel LSI measurement.

All specifications subject to change without notice_E.a