

CSF061.21

Lavoce

6.5" COAXIAL

FERRITE WOOFER
NEODYMIUM TWEETER MAGNET
STEEL BASKET DRIVER



- 1.2 INCH WOOFER COPPER VOICE COIL
- 0.55 INCH TWEETER COPPER VOICE COIL
- 92,5 dB/SPL SENSITIVITY
- 100 WATT PROGRAM POWER HANDLING
- FEM OPTIMIZED MOTOR AND SUSPENSIONS
- EXTENDED FREQUENCY RESPONSE AND CONSTANT DIRECTIVITY
- RESONANCE FREE AND HEAVY DUTY STEEL BASKET DESIGN
- OPTIMIZED BUILT-IN CROSSOVER

GENERAL SPECIFICATIONS

Nominal diameter	mm (in.)	165 - 20 (6.5 - 0.7)
Nominal impedance	Ω	8
Minimum impedance	Ω	6
Program power (1)	W	100
AES Power rating (2)	W	50
Sensitivity (3)	dB	92,5
Frequency range	Hz	90 ÷ 22000
Voice coil diameter	mm (in.)	30 - 14 (1.2 - 0.55)
Chassis material		Steel
Magnet material		Ferrite - Neodymium
Magnet dimensions	mm (in.)	90 x 40 x 15 (3.54 x 1.57 x 0.59)
Coil material		Copper
Former material		Polyimide
Cone material		Water Resistant Treated Paper - PEI
Surround material		Polycotton
Xmax (4)	mm (in.)	3,2 (0.12)
Xmech (5)	mm (in.)	4,2 (0.16)
Gap height	mm (in.)	4 (0.16)
Voice coil winding height	mm (in.)	8,5 (0.33)
Driver displacement volume	l (ft³)	8 (0.28)
Recommended enclosure	l (ft³)	6.2 (0.22)
Recommended tuning	Hz	Sealed

SMALL SIGNAL PARAMETERS

DC resistance	Re	Ohm	5,7
Resonance frequency	Fs	Hz	90
Moving mass	Mms	g (oz)	9,11 (0.32)
Compliance	Cms	mm/N	0,34
Force factor	BxL	N/A	6,09
Mechanical Q-factor	Qms		4,36
Electrical Q-factor	Qes		0,79
Total Q-factor	Qts		0,67
Equivalent air volume	Vas	l (ft³)	8,48 (0.3)
Voice coil Inductance	Le	mH	0,37
Diaphragm area	Sd	cm² (in.²)	132 (20.5)
Reference efficiency	Eta 0	%	0,75
Efficiency bandwidth product	EBP	Hz	114

SHIPPING INFORMATION

Net weight	kg (lb.)	1 (2.2)
Multipack size (8)	mm (in.)	381 x 365 x 220 (15 x 14.4 x 8.7)
Multipack weight	kg (lb.)	9,8 (21.6)

FREQUENCY RESPONSE AND IMPEDANCE

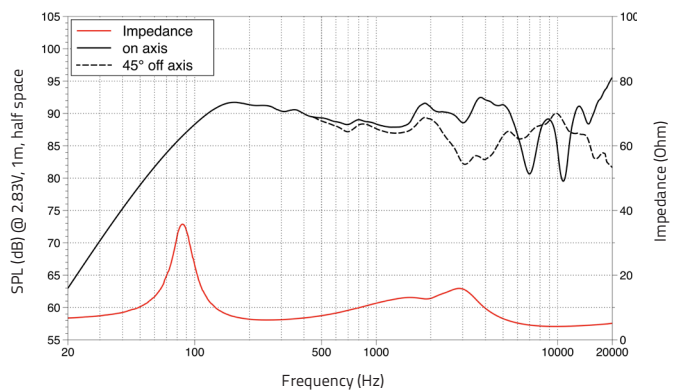

DIMENSIONS mm (in.)

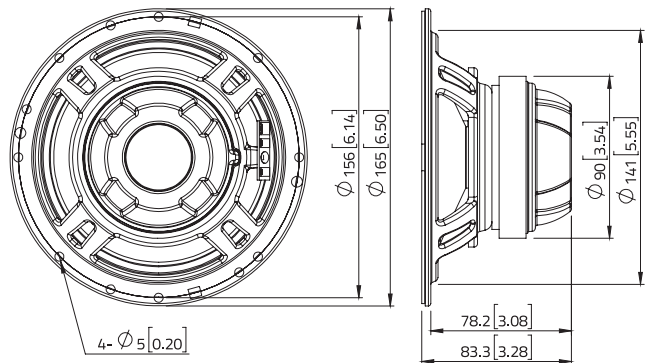

(1) Program power is defined as 3 dB greater than AES Power. (2) Tested for two hours using a continuous, band-limited pink noise signal as per AES 2-1984 Rev. 2003. Loudspeaker tested in free air. (3) From T/S parameters, measured with Klippel DA LPM module. (4) The Xmax is calculated as: $(Hvc - Hg)/2 + Hg/4$. Hvc is the voice coil height and Hg the gap height. (5) The Xmech is calculated as: $(Hvc - Hg)/2 + (Hg - 2)$. Hvc is the voice coil height and Hg the gap height. (6) Thiele-Small parameters are measured after preconditioning: a) at 20°C - 22°C, 50% humidity for 2 hours; b) by Klippel LSI measurement.

All specifications subject to change without notice_H.a

