

SAN216.00iP

Lavoce

21" SUBWOOFER

NEODYMIUM MAGNET
ALUMINIUM BASKET DRIVER

PRELIMINARY

- 1 OHM IMPEDANCE
- 6 INCH IN-OUT EDGEWOUND CCA VOICE COIL
- 99 dB/SPL SENSITIVITY
- 5000 WATT PROGRAM POWER HANDLING
- POWERSOFT IPALMOD COMPATIBLE
- ULTRA LOW DISTORTION DESIGN
- REDUCED POWER COMPRESSION THERMAL DESIGN
- 64,6 mm (2.5 INCH) PEAK TO PEAK MAXIMUM EXCURSION
- DOUBLE SILICON SPIDER AND TRIPLE ROLL SURROUND
- ALUMINIUM DEMODULATING RING



GENERAL SPECIFICATIONS

Nominal diameter	mm (in.)	530 (21)
Nominal impedance	Ω	1
Minimum impedance	Ω	1,05
Program power (1)	W	5000
AES Power rating (2)	W	2500
Sensitivity (3)	dB	99
Frequency range	Hz	35 ÷ 1000
Voice coil diameter	mm (in.)	152 (6)
Chassis material	Aluminium	
Magnet material	Neodymium	
Magnet dimensions OD x ID x h	mm (in.)	144,8 x 50,8 x 24 (5.7 x 2 x 0.94)
Coil material	Edgewound CCA	
Former material	Glass Fiber	
Cone material	Water Resistant Treated Paper + Water Proof Front Side Treatment	
Surround material	Polycotton	
Xmax (4)	mm (in.)	20,8 (0.82)
Xmech (5)	mm (in.)	32,3 (1.27)
Gap height	mm (in.)	18 (0.71)
Voice coil winding height	mm (in.)	50,6 (1.99)
Driver displacement volume	l (ft ³)	7,95 (0.28)
Recommended enclosure	l (ft ³)	200 (7.06)
Recommended tuning	Hz	40

SMALL SIGNAL PARAMETERS

DC resistance	Re	Ohm	0,7
Resonance frequency	Fs	Hz	36
Moving mass	Mms	g (oz)	481,6 (16.99)
Compliance	Cms	mm/N	0,04
Force factor	BxL	N/A	19,92
Mechanical Q-factor	Qms		3,45
Electrical Q-factor	Qes		0,19
Total Q-factor	Qts		0,18
Equivalent air volume	Vas	l (ft ³)	161,68 (5.71)
Voice coil Inductance	Le	mH	0,46
Diaphragm area	Sd	cm ² (in. ²)	1690 (261.95)
Reference efficiency	Eta 0	%	3,83
Efficiency bandwidth product	EBP	Hz	186

SHIPPING INFORMATION

Net weight	kg (lb.)	20,7 (45.6)
Multipack size (1)	mm	570 x 570 x 305
W x D x H	(in.)	(22.4 x 22.4 x 12)
Multipack weight	kg (lb.)	26,1 (57.5)

FREQUENCY RESPONSE AND IMPEDANCE

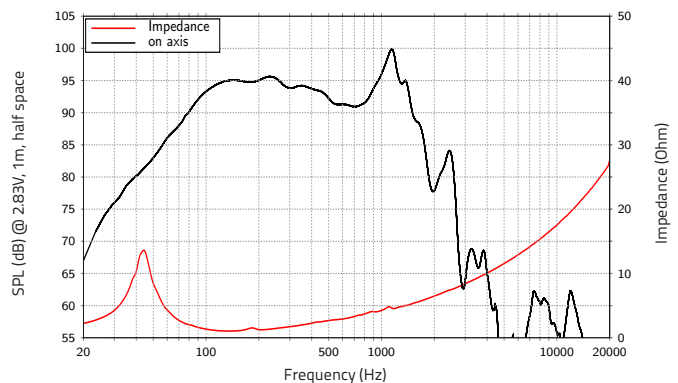

DIMENSIONS mm (in.)

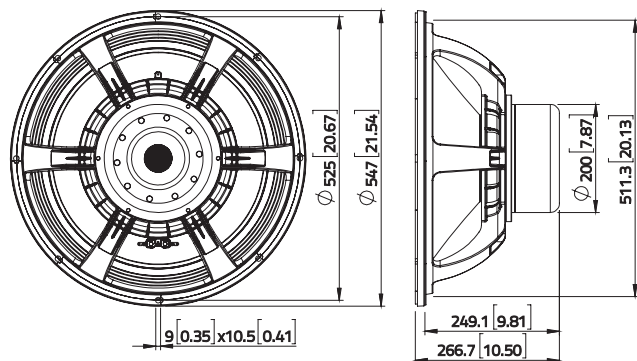

(1) Program power is defined as 3 dB greater than AES Power. (2) Tested for two hours using a continuous, band-limited pink noise signal as per AES 2-1984 Rev. 2003. Loudspeaker tested in free air. (3) From T/S parameters, measured with Klippel DA LPM module. (4) The Xmax is calculated as: $(Hvc - Hg)/2 + Hg/4$. Hvc is the voice coil height and Hg the gap height. (5) The Xmech is calculated as: $(Hvc - Hg)/2 + (Hg - 2)$. Hvc is the voice coil height and Hg the gap height. (6) Thiele-Small parameters are measured after preconditioning: a) at 20°C - 22°C, 50% humidity for 2 hours; b) by Klippel LSI measurement.

All specifications subject to change without notice_H.a

WWW.LAVOCESPEAKERS.COM



Lavoce Italiana

sales@lavocespeakers.com sales.cn@lavocespeakers.com