

# MAF061.50

Lavoce

## 6.5" MIDRANGE

FERRITE MAGNET  
ALUMINIUM BASKET DRIVER



- 1.5 INCH EDGEWOUND CCA VOICE COIL
- 96.5 dB/SPL SENSITIVITY
- 240 WATT PROGRAM POWER HANDLING
- FEM OPTIMIZED MOTOR AND SUSPENSIONS
- OPTIMIZED COOLING SYSTEM
- ALUMINIUM DEMODULATION RING
- TRIPLE ROLL SURROUND

### GENERAL SPECIFICATIONS

Nominal diameter	mm (in.)	165 (6.5)
Nominal impedance	Ω	8
Minimum impedance	Ω	6,4
Program power (1)	W	240
AES Power rating (2)	W	120
Sensitivity (3)	dB	96,5
Frequency range	Hz	150 ÷ 6000
Voice coil diameter	mm (in.)	38 (1.5)
Chassis material	Aluminium	
Magnet material	Ferrite	
Magnet dimensions	mm (in.)	120 x 60 x 20 (4.72 x 2.36 x 0.79)
Coil material	Edgewound CCAW	
Former material	Polyimide	
Cone material	Water Resistant Treated Paper	
Surround material	Polycotton	
Xmax (4)	mm (in.)	3,6 (0.14)
Xmech (5)	mm (in.)	6,1 (0.24)
Gap height	mm (in.)	6 (0.24)
Voice coil winding height	mm (in.)	10,3 (0.40)
Driver displacement volume	l (ft <sup>3</sup> )	0,529 (0.019)
Recommended enclosure	l (ft <sup>3</sup> )	5,04 (0.178)
Recommended tuning	Hz	150

### SMALL SIGNAL PARAMETERS

DC resistance	Re	Ohm	5,5
Resonance frequency	Fs	Hz	177
Moving mass	Mms	g (oz)	10,4 (0.37)
Compliance	Cms	mm/N	0,077
Force factor	BxL	N/A	10,54
Mechanical Q-factor	Qms		5,77
Electrical Q-factor	Qes		0,57
Total Q-factor	Qts		0,52
Equivalent air volume	Vas	l (ft <sup>3</sup> )	1,9 (0.07)
Voice coil Inductance	Le	mH	0,29
Diaphragm area	Sd	cm <sup>2</sup> (in. <sup>2</sup> )	132 (20.5)
Reference efficiency	Eta 0	%	1,78
Efficiency bandwidth product	EBP	Hz	311

### SHIPPING INFORMATION

Net weight	kg (lb.)	2,3 (5.1)
Multipack size (8)	mm (in.)	380 x 357 x 207 (15 x 14 x 8.1)
Multipack weight	kg (lb.)	19,3 (42.5)

### FREQUENCY RESPONSE AND IMPEDANCE

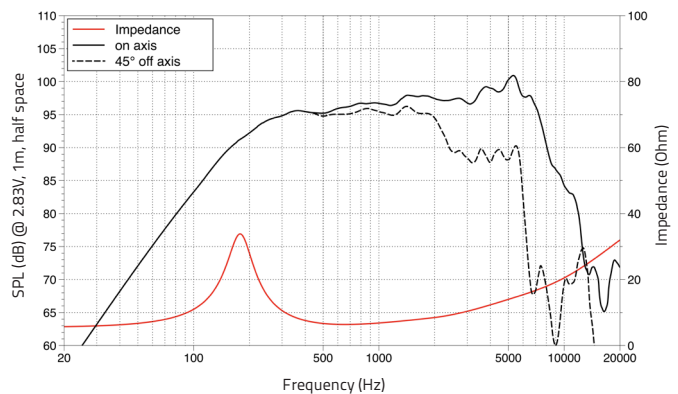

### DIMENSIONS mm (in.)

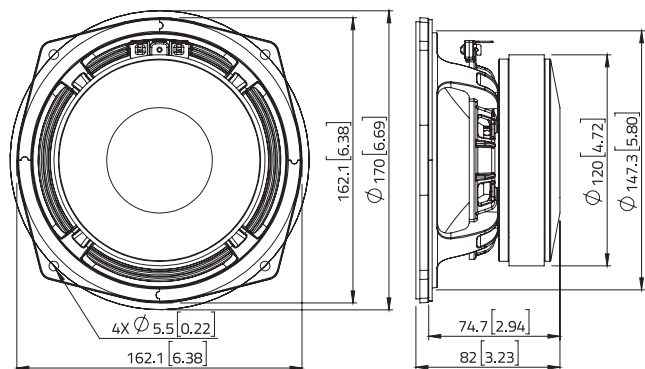

(1) Program power is defined as 3 dB greater than AES Power. (2) Tested for two hours using a continuous, band-limited pink noise signal as per AES 2-1984 Rev. 2003. Loudspeaker tested in free air. (3) From T/S parameters, measured with Klippel DA LPM module. (4) The Xmax is calculated as:  $(Hvc - Hg)/2 + Hg/4$ . Hvc is the voice coil height and Hg the gap height. (5) The Xmech is calculated as:  $(Hvc - Hg)/2 + (Hg - 2)$ . Hvc is the voice coil height and Hg the gap height. (6) Thiele-Small parameters are measured after preconditioning: a) at 20°C - 22°C, 50% humidity for 2 hours; b) by Klippel LSI measurement.

All specifications subject to change without notice\_H.a

