

SSF153.00

Lavoce

15" SUBWOOFER

FERRITE MAGNET
STEEL BASKET DRIVER



- 3 INCH VOICECOIL
- 97 dB/SPL SENSITIVITY
- 800 WATT PROGRAM POWER HANDLING
- FEM OPTIMIZED FERRITE MOTOR AND SUSPENSIONS
- SMOOTH FREQUENCY RESPONSE
- RESONANCE FREE AND HEAVY DUTY BASKET DESIGN

GENERAL SPECIFICATIONS

| | | |
|----------------------------------|----------|--------------------------------------|
| Nominal diameter | mm (in.) | 380 (15) |
| Nominal impedance | Ω | 8 |
| Minimum impedance | Ω | 6 |
| Program power (1) | W | 800 |
| AES Power rating (2) | W | 400 |
| Sensitivity (3) | dB | 97 |
| Frequency range | Hz | 50 ÷ 2600 |
| Voice coil diameter | mm (in.) | 75 (3) |
| Chassis material | | Steel |
| Magnet material | | Ferrite |
| Magnet dimensions OD x ID x h | mm (in.) | 190 x 85 x 20 (74.8 x 33.5 x 7.9) |
| Coil material | | Copper |
| Former material | | Glass Fiber |
| Cone material | | Water Proof Treated Paper |
| Surround material | | Polycotton |
| Xmax (4) | mm (in.) | 6,7 (0.26) |
| Xmech (5) | mm (in.) | 12,5 (0.5) |
| Gap height | mm (in.) | 10,5 (0.41) |
| Voice coil winding height | mm (in.) | 18,6 (0.73) |

SMALL SIGNAL PARAMETERS

| | | | |
|-----------------------|-------|-------------------------------------|-------------|
| DC resistance | Re | Ohm | 5,1 |
| Resonance frequency | Fs | Hz | 51 |
| Moving mass | Mms | g (oz) | 124 (4.34) |
| Compliance | Cms | mm/N | 0,08 |
| Force factor | BxL | N/A | 19,0 |
| Mechanical Q-factor | Qms | | 11,00 |
| Electrical Q-factor | Qes | | 0,56 |
| Total Q-factor | Qts | | 0,53 |
| Equivalent air volume | Vas | l (ft ³) | 82 (2.9) |
| Voice coil Inductance | Le | mH | 0,92 |
| Diaphragm area | Sd | cm ² (in. ²) | 855 (336.6) |
| Reference efficiency | Eta 0 | % | 1,9 |

SHIPPING INFORMATION

| | | |
|--------------------|------------------------------------|-----------------------------------------|
| Net weight | Kg (lb.) | 8,2 (18.1) |
| Multipack size (2) | mm x mm x mm (in. x in. x in.) | 480 x 430 x 400 (18.9 x 16.9 x 15.7) |
| Multipack weight | Kg (lb.) | 19,5 (43.0) |

FREQUENCY RESPONSE

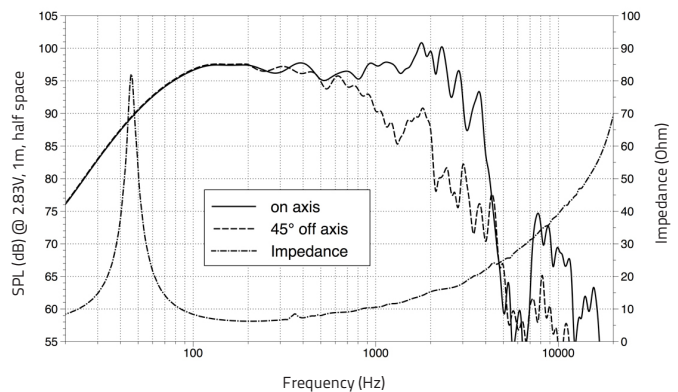

DIMENSIONS mm (in.)

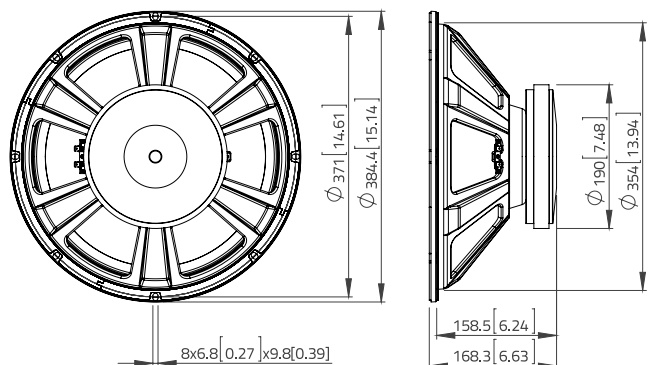

(1) Program power is defined as 3 dB greater than AES Power. (2) Tested for two hours using a continuous, band-limited pink noise signal as per AES 2-1984 Rev. 2003. Loudspeaker tested in free air. (3) From T/S parameters, measured with Klippel DA LPM module. (4) The Xmax is calculated as: $(Hvc - Hg)/2 + Hg/4$. Hvc is the voice coil height and Hg the gap height. (5) The Xmech is calculated as: $(Hvc - Hg)/2 + (Hg - 2)$. Hvc is the voice coil height and Hg the gap height. (6) Thiele-Small parameters are measured after preconditioning: a) at 20°C - 22°C, 50% humidity for 2 hours; b) by Klippel LSI measurement.

All specifications subject to change without notice_A.a

WWW.LAVOCESPEAKERS.COM



Lavoce Italiana

sales@lavocespeakers.com sales.cn@lavocespeakers.com